

# PROCEEDINGS OF SPIE

[SPIDigitalLibrary.org/conference-proceedings-of-spie](https://spiedigitallibrary.org/conference-proceedings-of-spie)

## Construction progress of WEAVE: the next generation wide-field spectroscopy facility for the William Herschel Telescope

Gavin Dalton, Scott Trager, Don Carlos Abrams, Piercarlo Bonifacio, J. Alfonso L. Aguerri, et al.

Gavin Dalton, Scott Trager, Don Carlos Abrams, Piercarlo Bonifacio, J. Alfonso L. Aguerri, Antonella Vallenari, Kevin Middleton, Chris Benn, Kevin Dee, Frédéric Sayède, Ian Lewis, Johannes Pragt, Sergio Picó, Nicholas Walton, Jeurg Rey, Carlos Allende, Émilie Lhomé, David Terrett, Matthew Brock, James Gilbert, Andy Ridings, Marc Verheijen, Ian Tosh, Iain Steele, Remko Stuik, Gabby Kroes, Neils Tromp, Jan Kragt, Dirk Lesman, Chris Mottram, Stuart Bates, Frank Gribbin, José Alonso Burgal, Jose Miguel Herreros, Jose Miguel Delgado, Carlos Martin, Diego Cano, Ramón Navarro, Mike Irwin, James Lewis, Eduardo Gonzales Solares, Neil O'Mahony, Andrea Bianco, Christina Zurita, Rik ter Horst, Emilio Molinari, Marcello Lodi, José Guerra, Andrea Baruffolo, Esperanza Carrasco, Szigfrid Farkas, Ellen Schallig, Vanessa Hill, Dan Smith, Janet Drew, Bianca Poggianti, Mat Pieri, Shoko Jin, Lilian Dominquez Palmero, Cecilia Fariña, Adrian Martin, Clare Worley, David Murphy, Andrea Hidalgo, Shan Mignot, Georgia Bishop, Steve Guest, Eddy Elswijk, Menno de Haan, Hiddo Hanenburg, Bernardo Salasnich, Divakara Mayya, Rafael Izazaga-Pérez, Luis Peralta de Arriba, "Construction progress of WEAVE: the next generation wide-field spectroscopy facility for the William Herschel Telescope," Proc. SPIE 10702, Ground-based and Airborne Instrumentation for Astronomy VII, 107021B (23 July 2018); doi: 10.1117/12.2312031

**SPIE.**

Event: SPIE Astronomical Telescopes + Instrumentation, 2018, Austin, Texas, United States

# Construction progress of WEAVE: the next generation wide-field spectroscopy facility for the William Herschel Telescope

Gavin Dalton<sup>\*\*\*a,b</sup>, Scott Trager<sup>c</sup>, Don Carlos Abrams<sup>d</sup>, Piercarlo Bonifacio<sup>f</sup>, J. Alfonso L. Aguerri<sup>g</sup>, Antonella Vallenari<sup>n</sup>, Kevin Middleton<sup>a</sup>, Chris Benn<sup>d</sup>, Kevin Dee<sup>d</sup>, Frédéric Sayède<sup>f</sup>, Ian Lewis<sup>b</sup>, Johannes Pragt<sup>i</sup>, Sergio Pico<sup>d</sup>, Nic Walton<sup>j</sup>, Juerg Rey<sup>d</sup>, Carlos Allende Prieto<sup>g</sup>, Emilie Lhome<sup>d</sup>, David Terrett<sup>a</sup>, Matthew Brock<sup>b</sup>, James Gilbert<sup>b</sup>, Andy Ridings<sup>d</sup>, Marc Verheijen<sup>c</sup>, Ian Tosh<sup>a</sup>, Iain Steele<sup>e</sup>, Remko Stuik<sup>i</sup>, Gabby Kroes<sup>i</sup>, Neils Tromp<sup>i</sup>, Jan Kragt<sup>i</sup>, Dirk Lesman<sup>i</sup>, Chris Mottram<sup>e</sup>, Stuart Bates<sup>e</sup>, Frank Gribbin<sup>d</sup>, Jose Alonso Burgal<sup>g</sup>, José Miguel Herreros<sup>g</sup>, José Miguel Delgado<sup>g</sup>, Carlos Martín<sup>d</sup>, Diego Cano<sup>d</sup>, Ramon Navarro<sup>i</sup>, Mike Irwin<sup>j</sup>, Jim Lewis<sup>i</sup>, Eduardo Gonzales Solares<sup>j</sup>, Neil O'Mahony<sup>d</sup>, Andrea Bianco<sup>l</sup>, Cristina Zurita<sup>g</sup>, Rik ter Horst<sup>i</sup>, Emilio Molinari<sup>m</sup>, Marcello Lodi<sup>m</sup>, José Guerra<sup>m</sup>, Andrea Baruffolo<sup>n</sup>, Esperanza Carrasco<sup>o</sup>, Szigfrid Farcas<sup>k</sup>, Ellen Schallig<sup>b</sup>, Vanessa Hill<sup>p</sup>, Dan Smith<sup>q</sup>, Janet Drew<sup>q</sup>, Bianca Poggianti<sup>n</sup>, Mat Pieri<sup>f</sup>, Shoko Jin<sup>a</sup>, Lillian Dominguez Palmero<sup>d</sup>, Cecilia Farina<sup>d</sup>, Adrian Martin<sup>m</sup>, Clare Worley<sup>j</sup>, David Murphy<sup>j</sup>, Andrea Hidalgo<sup>o,b</sup>, Shan Mignot<sup>f</sup>, Georgia Bishop<sup>a</sup>, Steve Guest<sup>a</sup>, Eddy Elswijk<sup>i</sup>, Menno de Haan<sup>i</sup>, Hiddo Hanenburg<sup>i</sup>, Bernardo Salasnich<sup>n</sup>, Divakara Mayya<sup>o</sup>, Rafael Izazaga-Pérez<sup>o</sup>, Luis Peralta de Arriba<sup>j</sup>

<sup>a</sup>RALSpace, STFC Rutherford Appleton Laboratory, OX11 0QX, UK; <sup>b</sup>Dept. of Physics, University of Oxford, Keble Road, Oxford, OX1 3RH, UK; <sup>c</sup>Kapteyn Institut, Rijksuniversiteit Groningen, Postbus 800, NL-9700 AV Groningen, Netherlands; <sup>d</sup>Isaac Newton Group, 38700 Santa Cruz de La Palma, Spain; <sup>e</sup>Astrophysics Research Institute, Liverpool John Moores University, IC2 Liverpool Science Park, 146 Brownlow Hill, Liverpool, L3 5RF, UK; <sup>f</sup>GEPI, Observatoire de Paris, Place Jules Janssen, 92195 Meudon, France; <sup>g</sup>Instituto de Astrofísica de Canarias, 38200 La Laguna, TF, Spain; <sup>h</sup>NOVA ASTRON, PO Box 2, 7990 AA, Dwingeloo, Netherlands; <sup>i</sup>Institute of Astronomy, Madingley Road, Cambridge, CB3 0HA, UK; <sup>k</sup>Konkoly Observatory, H-1525 Budapest, P.O.Box 67, Hungary; <sup>l</sup>Osservatorio Astronomico di Brera, INAF, via E. Bianchi 46, 23807 Merate (LC), Italy; <sup>m</sup>Fundación Galileo Galilei, INAF, Rambla José Ana Fernández Pérez, 7, 38712 Breña Baja, TF, Spain; <sup>n</sup>Osservatorio Astronomico di Padova, INAF, Vicolo Osservatorio 5, 35122, Padova, Italy.

<sup>o</sup>INAOE, Luis Enrique Erro 1, Tonantzintla, Puebla, Mexico; <sup>p</sup>OCA; <sup>q</sup>U. Herts.; <sup>r</sup>LAM.

## ABSTRACT

We present an update on the overall construction progress of the WEAVE next-generation spectroscopy facility for the William Herschel Telescope (WHT), now that all the major fabrication contracts are in place. We also present a summary of the current planning behind the 5-year initial phase of survey operations, and some detailed end-to-end science simulations that have been effected to evaluate the final on-sky performance after data processing. WEAVE will provide optical ground-based follow up of ground-based (LOFAR) and space-based (Gaia) surveys. WEAVE is a multi-object and multi-IFU facility utilizing a new 2-degree prime focus field of view at the WHT, with a buffered pick-and-place positioner system hosting 1000 multi-object (MOS) fibres, 20 integral field units, or a single large IFU for each observation. The fibres are fed to a single (dual-beam) spectrograph, with total of 16k spectral pixels, located within the WHT GHRIL enclosure on the telescope Nasmyth platform, supporting observations at R~5000 over the full 370-1000nm wavelength range in a single exposure, or a high resolution mode with limited coverage in each arm at R~20000. The project has experienced some delays in procurement and now has first light expected for the middle of 2019.

**Keywords:** Multi-Object Spectroscopy, Fibre Optics, High Resolution Spectroscopy

---

\* [gavin.dalton@stfc.ac.uk](mailto:gavin.dalton@stfc.ac.uk); Tel +44 1235 446401

## 1. INTRODUCTION

The WEAVE<sup>[1,2]</sup> project began in early 2010 with a series of national meetings within the partner countries (The UK, The Netherlands, and Spain) of the Isaac Newton Group of telescopes, aimed at developing a comprehensive strategy for the 4.2 William Herschel Telescope (WHT) for the next decade. These meetings identified the need for a dedicated high-multiplex spectroscopic facility to complement upcoming large-scale survey programs in Galactic and extra-Galactic astrophysics, particularly from new facilities such as ESA's Gaia satellite<sup>[3]</sup> and the European Low Frequency Array (LOFAR<sup>[4]</sup>). Gaia is already providing<sup>[5,6]</sup> an unprecedented picture of the structure and dynamics of the Milky Way from measurements of precise positions and parallaxes for  $10^9$  stars with ( $V \leq 20$ ) over the whole sky, with still more to come, but is unable to measure the radial component of velocity for the majority of the stars ( $V > 16.5$ ), and has limited spectroscopic capabilities that restrict chemical abundance measurements to only the brightest ( $V < 12$ ) stars in the survey. LOFAR's ongoing surveys will detect more than  $10^7$  radio sources from high-resolution radio imaging at 30, 60, 120 and 200 MHz over 10000 square degrees of the Northern Sky, but the majority of these are continuum detections with no spectroscopic information to provide redshifts or information on the evolutionary state of the sources. APERTIF<sup>[7]</sup> will provide detailed information on the kinematics and dynamics of neutral hydrogen in galaxies at low and intermediate redshifts ( $z \sim 0.3$ ), but complementary observations are required at visible wavelengths to connect these data with the stellar populations and star-formation activity.

WEAVE was initially developed as a joint project between the UK, Spain and the Netherlands, but the project has been open to wider participation, and the partnership now includes France, Italy, the Konkoly Observatory and INAOE. A number of other individuals and institutes have contributed to join the WEAVE science consortium, but are not participating directly in the construction of the facility.

The final design of WEAVE was reported in 2016<sup>[8]</sup>, and the aim here is not to repeat what has already been set out, but rather to report on the progress towards realization of the design. Many of the WEAVE systems are now close to completion, but there have been some surprises and the inevitable delays along the way. As before, many of the details of the individual systems are reported elsewhere in these proceedings<sup>[9-22]</sup>, and so we aim here to focus on the implications of those details for the final performance and schedule: In Section 2 we review the overall instrument parameters. Section 3 covers aspects of the new prime focus infrastructure while Section 4 reports on early testing results for the WEAVE fibre positioning system. Details of the fibre system itself, and the impact of procurement delays are discussed in Section 5. Progress on the optical components and mechanics of the spectrograph is presented in Section 6, while Section 7 discusses the diverse components of the software infrastructure required to operate and exploit the WEAVE facility. Section 7 includes the description of a set of ongoing detailed operational simulations that are designed to test the end-to-end operation of the software infrastructure and validate the final scientific performance. We conclude with a summary of the overall project schedule to completion as it sits at the time of writing, and a brief overview of the science surveys that will occupy the first 5 years of WEAVE operations.

## 2. PARAMETERS OF THE WEAVE FACILITY

Telescope, diameter	WHT, 4.2m
Field of view	$2^\circ \varnothing$
Number of fibers	960 (plate A)/940 (plate B)
Fiber size	1.3"
Number of small IFUs, size	20 x 11"x12" (1.3" spaxels) (plate B)
LIFU size	1.3'x1.5' (2.6" spaxels)
Low-resolution mode resolution	5750 (3000–7500)
Low-resolution mode wavelength coverage (Å)	3660–9590
High-resolution mode resolution	21000 (13000–25000)
High-resolution mode wavelength coverage (Å)	4040–4650, 4730–5450 5950–6850

**Table 1: Summary of WEAVE's capabilities.**

### 3. THE WEAVE PRIME FOCUS ASSEMBLY

The WHT prime focus assembly is comprised of the WEAVE corrector(WCS), the prime focus instrument rotator(WRS), and the new top-end support structure, including the focus translation system (FTS). The top-end was delivered in 2016<sup>[23]</sup>, to the IAC for flexure testing. However, these tests proved unsatisfactory in the laboratory environment, thought to be largely due to flexure of the lifting frame employed for the tests, which is considerably less substantial than the WHT top end ring. The system was then delivered to the telescope for mounting trials, and successfully mounted after some minor rework of the lifting frame mounting points. (Figure 1). Flexure measurements were carried out by mounting a FARO Vantage laser-tracker head on the main telescope cube structure and taking multiple repeat measurements of a set of SMRs fixed at various locations on the new top end and the outer ring structure. These measurements were compared to a set of similar measurements carried out on the existing top-end inner ring structure with the overall conclusion that the new system exhibited around 730 $\mu$ m of movement between the zenith and 30° elevation (compared with a specification limit of 400 $\mu$ m), implying that some reworking of the FTS units was required. A subsequent re-analysis of the system has shown that considerable improvement should be achieved by relatively minor modifications to the FTS units and the mounting arrangement to the outer ring, and these are in manufacturing for a scheduled re-test on-telescope at the end of July 2018.

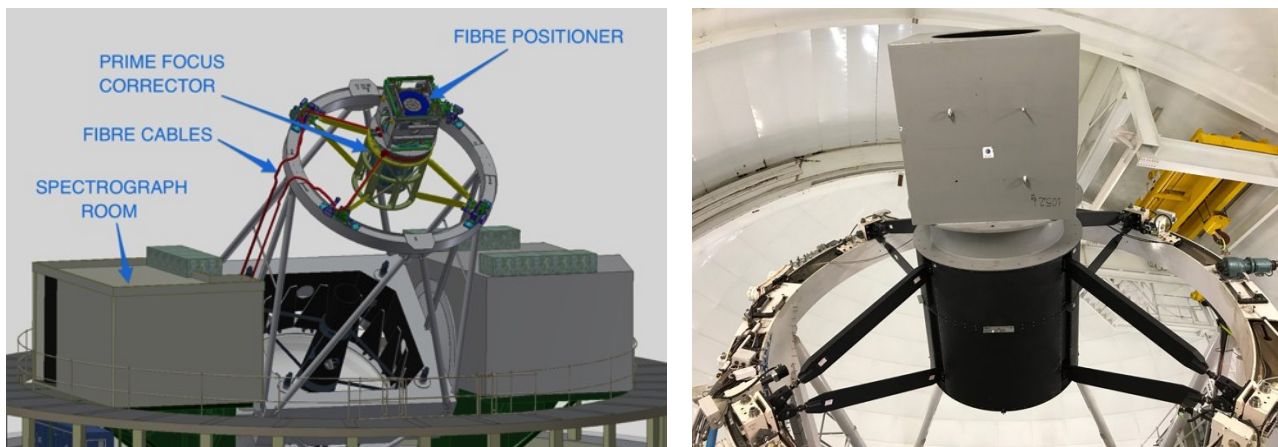

**Figure 1:** (left) Illustration of the new configuration for WEAVE showing the new top end structure and the route of the fibre cables to GHRIL. (right) The new top-end installed on the telescope for the first time, with focus translation units (4), new spiders and centre-section, together with mass/volume dummies for the corrector, rotator and fibre positioner. For scale, the positioner is approximately 1.8m on a side.

**Figure 2:** (left) The new top end under test at the IAC, complete with full-size mass dummies for the positioner, corrector and instrument rotator. (right) Handling frame (red) and access platform for the WEAVE top end storage and maintenance.



**Figure 3:** Lens 1 undergoing final testing at Kiwistar Optics.

The 6 lenses for the prime focus corrector have been polished by Kiwistar Optics and lenses 2-5 coated by EMF. The project decided to leave the 1100mm diameter L1 (figure 3) uncoated and accept the loss in performance rather than risk failure of a coating on an optic of this size. A report on the final testing of the lens elements is presented elsewhere in this conference<sup>[9]</sup>.

The assembly of the corrector is now being progressed through a contract with NTE-SENER in Barcelona<sup>[10]</sup>. The design of the corrector was constrained with an assumption that the final alignment should be achievable by mechanical alignment tolerances, and this was found to yield a solution that delivers 0.6" (FWHM) panchromatic image quality over the full field<sup>[8]</sup>. Given the current schedule for delivery of the various subsystems to La Palma, it appears that there will be sufficient time available to mount ING's existing Shack-Hartmann camera within the positioner mass dummy, so that the as-built image quality can be fully characterized before the positioner is installed.

The mechanical design for the lens mounts draws heavily on the design used for DECam<sup>[25]</sup>, using radial and axial RTV pads to support the lenses within their cells. The design is somewhat complicated by the presence of the air-spaced ADC elements, and the fact that the physical cylindrical edges of the as-made lenses are not all parallel or concentric to the optical axis of the assembly, a design choice made to simplify polishing of the lens surfaces and reduce the overall cost of the corrector.

The final element of the new prime focus assembly is the instrument rotator, currently under construction at IDOM in Bilbao<sup>[11]</sup>. The design of this element has been evolved somewhat by IDOM to arrive at a solution using with much better stiffness-to-weight ratio than the original concept. The rotator is accompanied by a full cable wrap system which will support the full complement of MOS, mIFU and LIFU fibres in addition to the control cables for the fibre positioner, a total of more than 50 cables and 3500 fibres. The space constraints implied by the optical design imply that the rotator sits ahead of the rear element of the rear element of the corrector, allowing space for a moveable focal plane imaging system to patrol in front of the fibres.

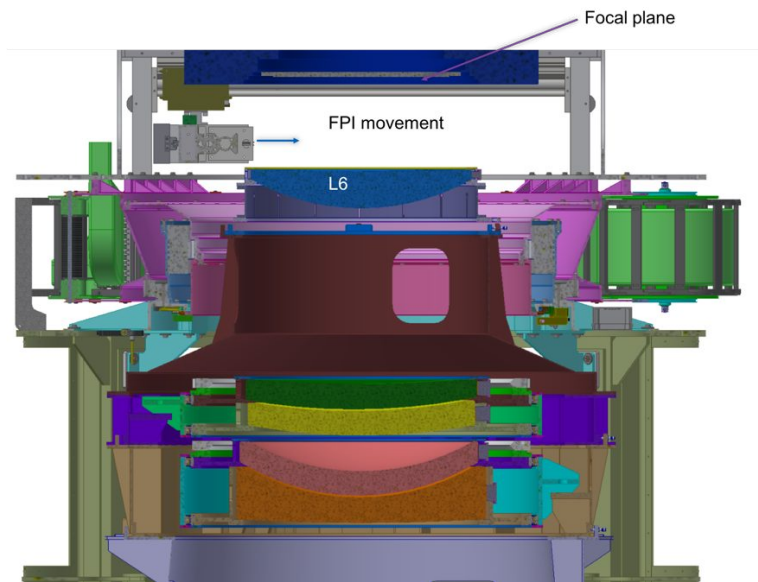

**Figure 4:** Cross-section view of the rotator unit (magenta) and cable wrap (green) mounted around the rear element of the corrector and showing the accommodation envelope for the movement of the focal plane imager (FPI) between the lens and the focal plane.

## 4. FIBRE POSITIONER TESTING

The fibre positioner (Figure 6) has now been fully assembled in the laboratory in Oxford. To summarize the design, the positioner consists of a pair of Cartesian robots, each in an X2YZ $\theta$  configuration with a gripper unit and camera mounted on the  $\theta$ -stage. These robots work on a pair of field plates that can be switched between the observing position at the corrector focus, and the configuration position by means of a tumbler structure. A third robot with an X2Y configuration is mounted between the rear element of the corrector and the focal plane with cameras imaging the sky and the field plate to allow for focus measurement and on-sky determination of the astrometric parameters required for accurate positioning.

Each of the 13 robot axes is controlled by a dedicated Bosch Rexroth Indradrive controller which deals with the servo-level controls. The 13 controllers and the two gripper units are linked via a local Sercos-III network to a Bosch Rexroth MLC. The MLC is configured so that the X2Y $\theta$  and X2Y combinations function as coordinated robots, with the Z-axes and the gripper units functioning separately. The MLC runs a simple sockets interface to a high-level Linux control computer which deals with the algorithms for determining each move, such that the two positioning robots operate in a client-server mode with no prior knowledge of the exact sequence that will be followed to set up a field.

In operation, the software aims to move from one field to the next with the minimum number of robot moves, and so fibres will be moved to their 'park' positions at the edge of the field only if no direct moves are possible. In practice this means that around 30-40% of the fibres can be moved directly. Initial testing<sup>[13]</sup> without recourse to the parallel implementation of some parts of the move sequence show that the out-of-the box performance is around 5.5s/move, and this is consistent with achieving the desired 4s performance once the sequence is fully optimized<sup>[26]</sup>.

The positioner is currently fully disassembled for anodizing of all the main structural components and will be put together for a final build in autumn of 2018 to await the arrival of the fibre bundles.

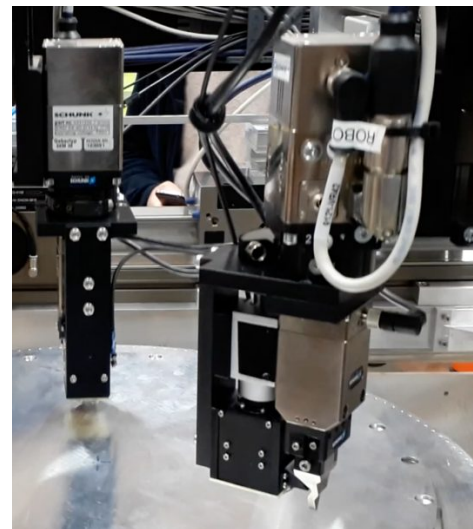
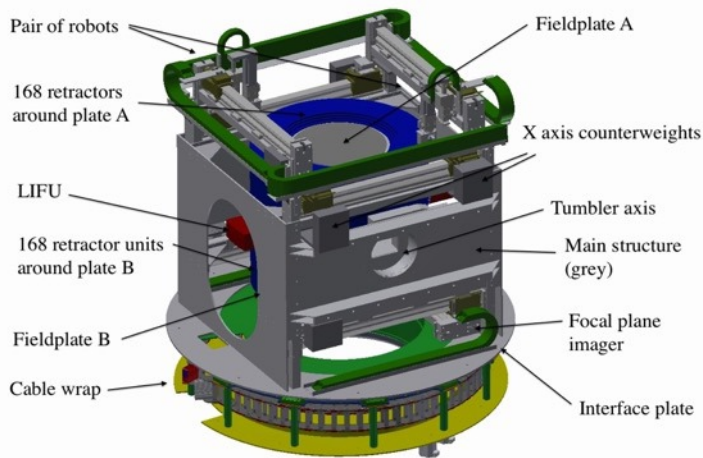

**Figure 5:** (*left*) The general layout of the fibre positioner system. (*right*) Close-up of the two robots in action, showing the  $\theta$  axes, gripper units and one of the plate/fibre viewing cameras.

## 5. FIBRE SYSTEM PROGRESS

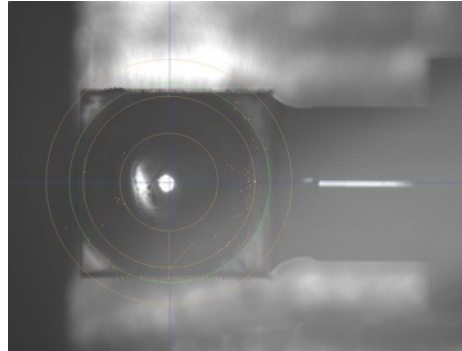

**Figure 6:** (left) The 24 fibres of the prototype bundle in place on the test setup for automatic measurements. (above) Closeup of the lensed top surface of one of the prisms showing the excellent centration achieved.

The initial version of the prototype fibre bundle<sup>[8]</sup> was measured at GEPI and then sent to Oxford for lifetime testing in one of the positioner's retractor units. A subset of the fibres were each tested for up to 4x the expected life cycle using a prototype single YZ0 axis with gripper unit. The bundle was then returned to GEPI for re-testing (Figure 6) and showed no evidence of degradation. The bundle was then shipped to La Palma, but 11 of the 24 prisms became detached during shipping due to a packaging error. The bundle was attached to the telescope and run through an accelerated cycle of simulated moves over a period of 1 month, before being returned to Paris for final re-testing. The FRD performance of a typical fibre is shown in Figure 9b, and shows no degradation due to the lifetime cycling operations, with losses for the prototype fibres between 3 and 5% between the  $f/3.2$  input and  $f/3/1$  output. The bundle was then returned to SEDI for re-termination with new prisms, re-tested in Paris and then sent to Oxford for test integration into the now-build positioner assembly (Figure 7a).

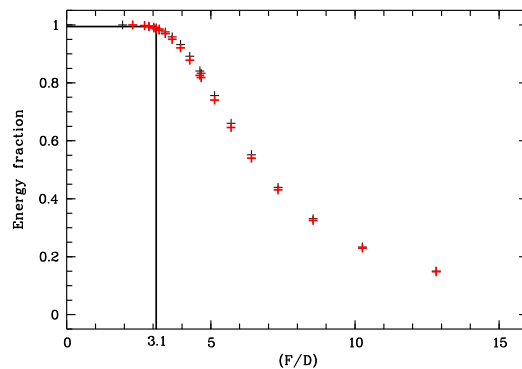
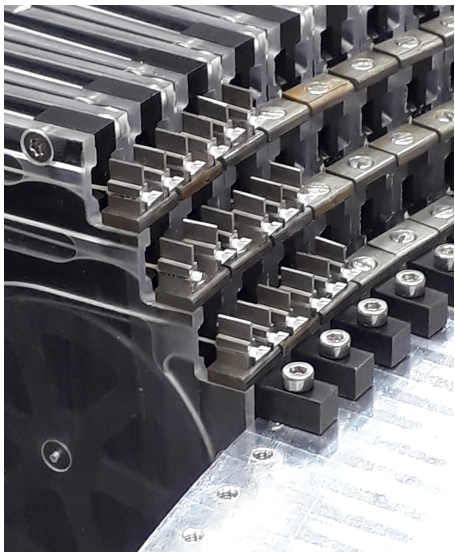
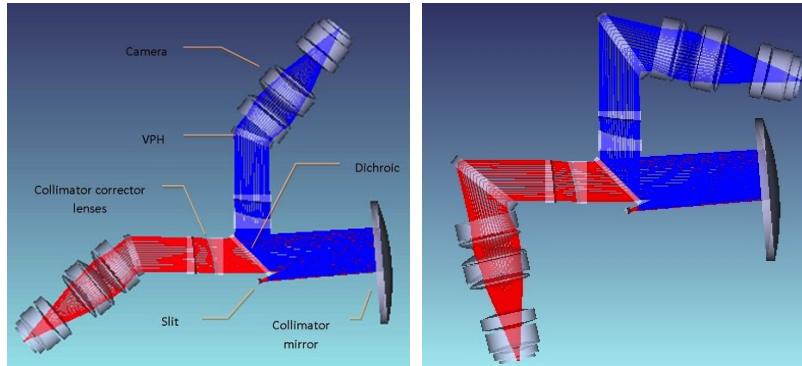

**Figure 7:** (a, left) The 24 fibres of the prototype bundle mounted in a set of 4 retractors in the positioner (one prism was lost during integration). (b, above) Final FRD measurement of a typical fibre with an  $f/2.7$  input to the lensed prism and an  $f/3.1$  output window matched to the spectrograph collimator.

Unfortunately, delays in the completion of the fibre test-bench, and knock-on delays in placing procurements for the various components of the system now imply that the final delivery of fibre cables to the project will be June 2019, and this now drives the overall schedule. On the positive side, the first full 96-fibre cable (4 slitlets to be fed from 16 retractors of six fibres each) has now been delivered and is under test.

## 6. REALISING THE WEAVE SPECTROGRAPH

The dual-beam spectrograph manufacture is in progress<sup>[15]</sup>, with a full set of lenses for the blue-arm now close to completion. The optical layout is reproduced in Figure 8 (from ref [8]). In brief summary, each camera consists of 8 lenses, with an aspheric surface on the first lens. The collimator is catadioptric, and arranged such that the spherical transmissive elements are placed after the dichroic to allow optimization of the coating performance for each arm. The camera designs are constrained to use the same surface prescriptions on each pair of lenses, but allow spacing changes for optimization.



**Figure 8** WEAVE optical layout, low (left) and high (right) resolution mode.

The collimator mirror and camera lenses 2-8 for each camera are being polished at INOAE as an in-kind contribution to the project. The red camera set is complete, with two lenses still remaining to be coated at CIO in Mexico. Coating performance for the remaining lenses, a critical element of the overall WEAVE performance, is within specifications.

The collimator lenses and Camera L1s have been polished by TNO in the Netherlands, although L1 has not yet been made to specification and will require corrective work from the NOVA lab. The corrector lenses have been completed, but one of the red-arm F2 elements suffered a catastrophic failure in coating at Schott (Figure 9). A new blank has been obtained for this element and is in polishing, but it was possible to redirect the coating of the blue element to be used in the red arm to facilitate the spectrograph assembly process.

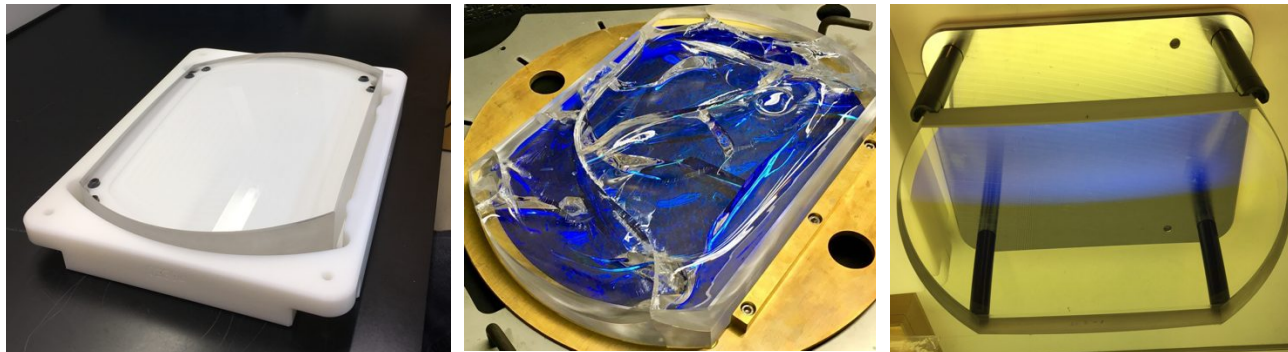

**Figure 9** (left) Red F2 collimator lens at TNO after polishing. (centre) After catastrophic failure at Schott. (right) Blue-arm F2 lens coated for the red arm.

The dichroic for the spectrograph has been completed by Materion, and shows good performance in line with the specifications. The 5 VPH gratings have been manufactured by KOSI<sup>[18]</sup>. The blue HR grating shows reduced throughput relative to the specification, which appears to be the result of an error in the prescription of the coatings applied to the substrates in the Netherlands prior to manufacture. This is still under investigation, and we are considering a repeat manufacturing run for this grating to recover the expected performance. The other 4 gratings match the specifications well.



## 7. SOFTWARE SYSTEMS

All the Final Design Reviews for the software systems are now complete. In September 2017 we ran an exercise<sup>[24]</sup> to simulate a full week of observations using input catalogues and template spectra from the science teams. Configured fields were ‘observed’ using the WEAVE image simulator<sup>[14]</sup>, and then passed to the data flow systems for processing, analysis and archiving. These ~50,000 spectra were then returned to the science teams for evaluation. The primary motivation for this exercise was to validate the information flows and provide a first pass diagnostic of the survey planning. A typical output spectrum from the StePS survey simulation is shown in Figure 10.

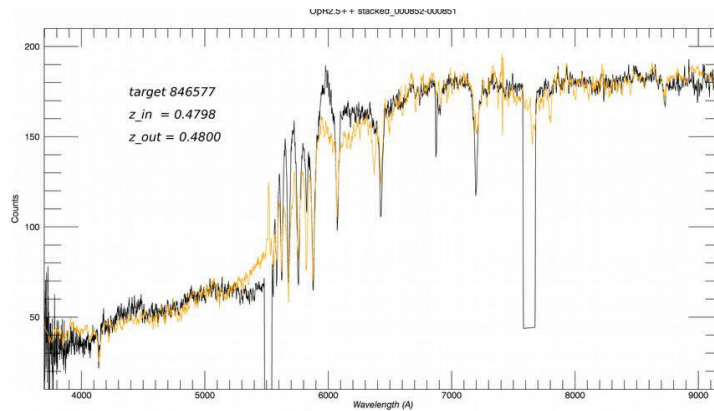

**Figure 10** Example output from the simulation exercise of 2018 showing a stitched blue and red-arm spectrum for a galaxy from the COSMOS field (7 hour stacked exposure from 21 18-minute frames). The gaps in the spectrum around 5500Å and 7700Å are the gaps between the two detectors in the blue and red arms, respectively.

The success of the simulation exercise led to planning a second-pass which is now in-progress. This incorporates full survey scheduling<sup>[22]</sup> over 3 full semesters, from each of which we draw a single week of observations to pass through the simulation and processing chain. The full chain now incorporates seeing and transparency variations appropriate to real measurements from the telescope in 2016/17, and a sky-spectrum for each field drawn from ESO skycalc<sup>†</sup> with appropriate moonlight and absorption for the target position. Observations using the LIFU mode are also being simulated for the first time to validate those aspects of the data flow. Simulated observations are passed to the telescope and ‘observed’, then fed into the data chain with real cadences where they can be picked up by the quick-look quality control software pipeline (Figure 11), and fed into the processing chain and archive.

<sup>†</sup> <https://www.eso.org/observing/etc/doc/skycalc/helpskycalc.html>

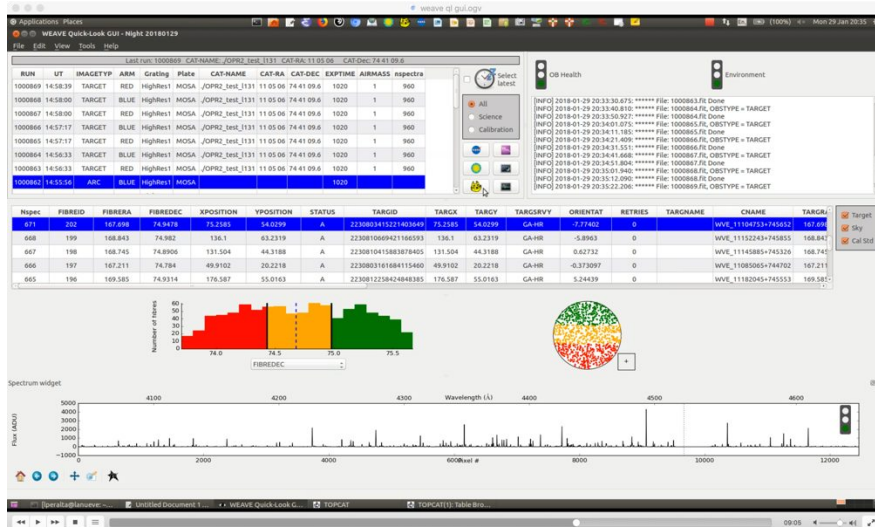

**Figure 11** Example screen from the real-time quality control pipeline that will run at the telescope during all WEAVE operations. Individual spectra can be inspected, and global properties of the full set of spectra for each field can be viewed for diagnostic purposes.

## 8. SUMMARY, SCHEDULE AND PROSPECTS

Technically, the project is on-track, with no apparent issues for the overall performance. The overall schedule is now completely driven by the expected final delivery of the MOS fibre cables, and this should see the full instrument assembled at the telescope and on-sky at the end of 2019. The core survey programme will commence in 2020, with 5 years of observations currently guaranteed. The specific details of the science programmes are largely unchanged, but are the subject of regular reviews by the project oversight boards.

## 9. ACKNOWLEDGEMENTS

The WEAVE project is supported through the Isaac Newton Group Partnership and by grants from the UK Science and Technology Facilities Council (STFC), the Nederlandse Organisatie voor Wetenschappelijk Onderzoek (NWO), the Nederlandse Onderzoekschool voor Astronomie (NOVA), the Instituto de Astrofísica de Canarias (IAC), the Région Île de France and the Instituto Nazionale di Astrofisica (INAF), as well as by further in-kind contributions from the Centre National de la Recherche Scientifique (CNRS), INAOE, and Konkoly Observatory. We would also like to thank René Rutten, Roland Bacon, Axel Yanes, Eli Atad, Paul Jolley, Ian Parry, Peter Doel, Jorge Sanchez, Gary Hill, Matt Bershady, Riccardo Schiavon, Graham Murray, Paolo Spano, Olivier Schnurr, Barry Fell, Roger Haynes, Vicente Sanchez, Matt Bershady, Graham Murray, Phil Rees, Martin Whalley, Nigel Dipper, Ian Tosh, Steven Beard, Martin Caldwell, Davide Bruzzi, Nicholas Rubies, Alan Bridger, Maurizio Chavan and Nigel Morris for their assistance in project reviews.

## REFERENCES

- [1] Balcells, M., et al., Proc. SPIE 7735 (2010).
- [2] Dalton, G., et al., Proc. SPIE, 8466, 23 (2012).
- [3] Prusti, T. et al., EAS 45, 9 (2011).
- [4] van Haarlem, M., EAS 15, 431 (2005).
- [5] Gaia Collaboration, A&A 595, A1 (2016)
- [6] Gaia Collaboration, arXiv 1804.09365 (2018)
- [7] Oosterloo, T., et al., Proceedings of ISKAF Science Meeting (2010).
- [8] Dalton G., et al., Proc SPIE, 9908, 1G (2016)

- [9] Bogunivic, D., et al., Proc SPIE, 10700, 118 (2018)
- [10] Dalmases, F., et al., Proc SPIE, 10706, 4 (2018)
- [11] Murga, G., et al., Proc SPIE, 10700, 235 (2018)
- [12] Delgado, J. M., et al., Proc SPIE, , (2018)
- [13] Schallig, E., et al., Proc SPIE, , (2018)
- [14] Dalton, G. et al., Proc SPIE 9913, 2X (2016)
- [15] Stuik, R., et al., Proc SPIE, , (2018)
- [16] Izazaga, R., et al., Proc SPIE, , (2018)
- [17] Izazaga, R., et al., Proc SPIE, , (2018)
- [18] Bianco, A., et al., Proc SPIE, , (2018)
- [19] Bates, S., et al., Proc SPIE, , (2018)
- [20] Salasnich, B., et al., Proc SPIE, , (2018)
- [21] Pico, S., et al., Proc SPIE, , (2018)
- [22] Fariña, C., et al., Proc SPIE, , (2018)
- [23] Casalta, J.M., et al., Proc SPIE, 9912, 200 (2016)
- [24] Jin, S., et al., MNRAS *in preparation*.
- [25] Doel, P., et al. Proc SPIE, 8446, 6FD (2012)
- [26] Lewis, I. et al., Proc SPIE 9147, 34L (2014)